

wilson

Refresh™

UNDER BENCH BOILING AND
CHILLED WATER SYSTEM



We're at your service.
SINCE 1930

wilson
HOT WATER

We're at your service.
SINCE 1930

wilson
REFRESH™



An all in one tap system that boils and chills...

The **wilson REFRESH** is the ideal appliance for filtered boiling and chilled water in the office or home. The **wilson REFRESH** has been designed for ease of use and developed incorporating robust and reliable technology that delivers durability with stylish design. Importantly the **wilson REFRESH** is manufactured in Australia to Australian Standards

Being modular in design allows for flexibility in installation. The tap and boiling/chilled units are simple to install with flexible tubing and easy-connect fittings. Leak detection sensors are fitted with automatic shut off should a leak occur.

The **wilson REFRESH** is available in five combinations capable of delivering 90 and 120 cups of boiling water and a refreshing 65 or 125 glasses of chilled water per hour.



model	W90B/65C	W90B/125C	W120B/125C	W90B	W120B
Cups per hour (boiling/chilled)*	90/65	90/125	120/125	90 Boiling/Ambient	120 Boiling/Ambient
Dimensions (Boiler)	300Wx300Dx406H	300Wx300Dx616H	300Wx300Dx616H	300Wx300Dx406H	300Wx300Dx616H
Dimensions (Chiller)	315Wx415Dx365H	340Wx440Dx535H	340Wx440Dx535H		
Tray	T012	T011	T011	T022	T022
Weight (Approx)	40kg	45kg	50kg	15kg	20kg
Minimum Water Supply Pressure	250kPa	250kPa	250kPa	250kPa	250kPa
Maximum Water Supply Pressure	1600kPa	1600kPa	1600kPa	1600kPa	1600kPa
Plumbing Connections	15mm BSP male	15mm BSP male	15mm BSP male	15mm BSP male	15mm BSP male
Input Power Boiler/Chiller (W)	1800W/260W	1800W/390W	2400W/390W	1800W	2400W
Electrical Connections	2x3pin10A plug	2x3pin10A plug	2x3pin10A plug	1x3pin10A plug	1x3pin10A plug
Filter BR 540	Yes	Yes	Yes	Yes	Yes

* Chilled Water delivery based on 20°C incoming water temp, 10°C chilled water, 32.2°C ambient air temp



It's all at your finger tips...

The **wilson refresh** is fitted with a 5 micron filter that minimises chlorine taste and odour that can affect the taste of water and beverages. The filter also reduces lime scale build up that can lead to increased maintenance costs... a bonus for facility managers. An automatic 'filter change' LED light indicates when a filter change is required with the replacement effortless due to a simple twist and turn bayonet design.

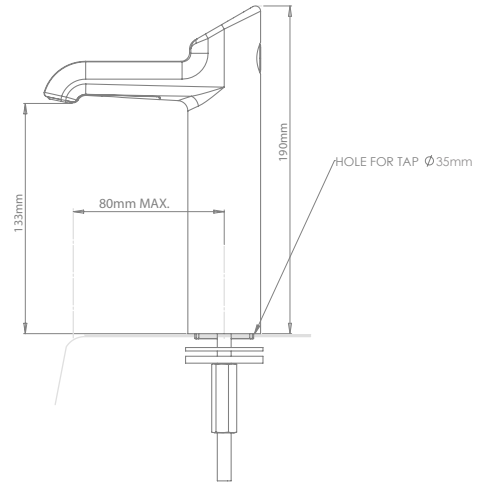

Plumbing Connections

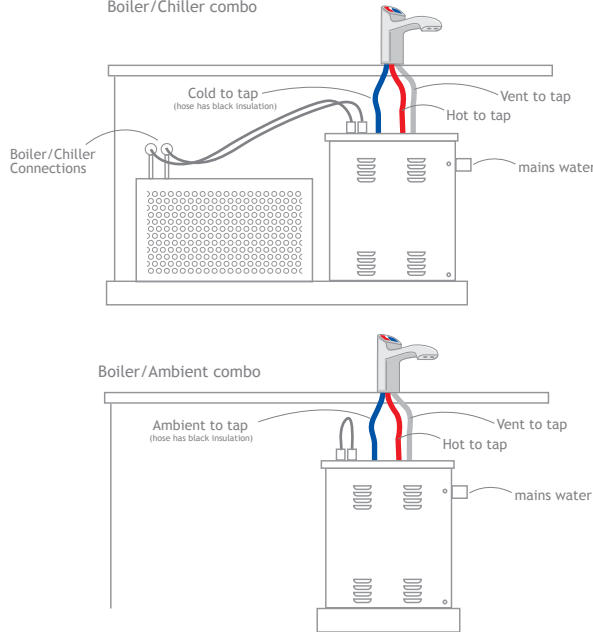

The solid brass, chrome plated **wilson refresh** tap is stylish in design with an easy to clean finish while the electronic touch pad makes for simple operation. Programming of the **wilson refresh** is uncomplicated and achieved via the touch pad. A programmable safety interlock function is fitted. The automatic 'sleep mode' powers the boiling water down to 65°C when lights are switched off and the unit has not been in use for 1 hour. The tap is manufactured with the highest quality materials, backed by solid engineering then delivering reliability and low cost maintenance.

- 12 month warranty
- Specifications are subject to change without notification



W120B/125C

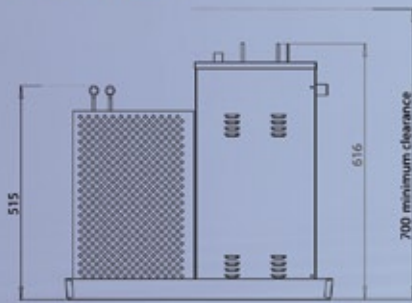

W90B/125C

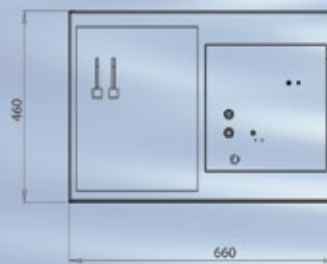
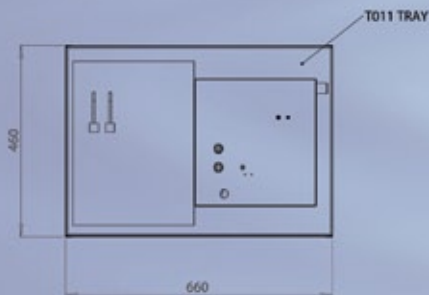
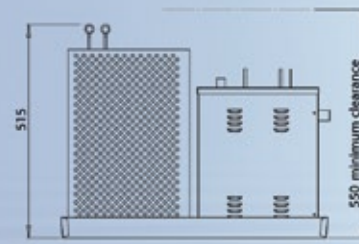

W90B/65C

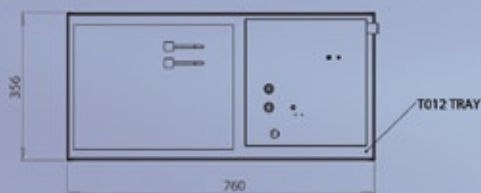
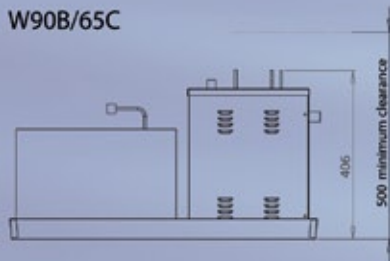

Note for installation:

- Units can be swapped left to right or rotated to suit installation, but side marked FRONT on chillers must have free space to circulate air. A door vent (supplied) or other alternative ventilation is required for the chiller.
- Ideally the 125C chiller grille must face directly into supplied door vent or other ventilation.
- Two supplied flexible hoses join the chiller to the boiler (for hot/ambient models the 2 connections on the boiler are bridged with a flexible hose)
- Ideally a twin 240VAC 10A powerpoint is installed in the underbench area.
- A tray must be used to contain both chiller and boiler for the leak detector cutout to operate.
- 5 micron water filter is housed in boiler
- Optional tray sizes available

12 month warranty.

Specifications are subject to change without notification.

wilson
HOT WATER