

installation

INSTRUCTIONS

Pressure and Temperature Relief Valve

PTR

TYPICAL INSTALLATION OF CONTROLLED PRESSURE HOT WATER SYSTEM

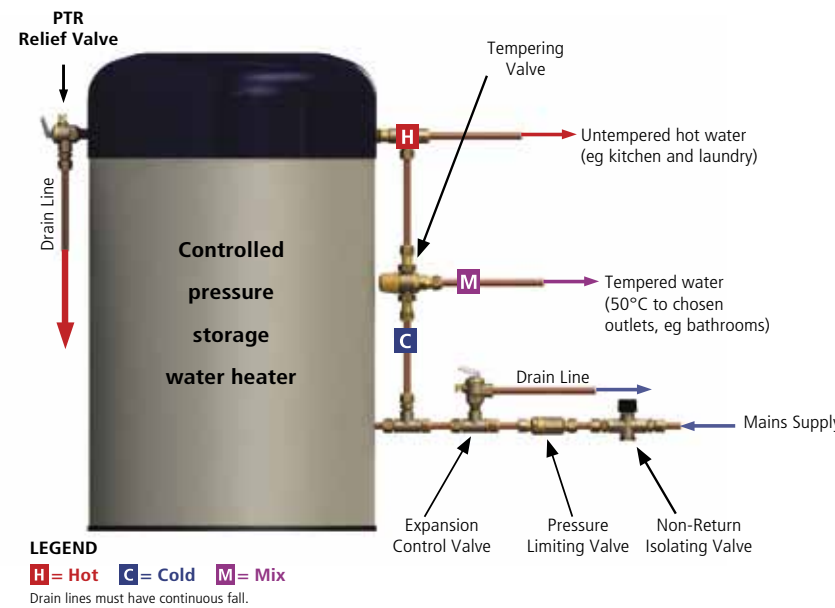

The tempering valve may be installed at the point of use, but there must be a minimum 1 metre pipe run between the valve and the outlet tap.

Caution: Water escaping from the drain line may be hot and could cause scalding. This valve is a Safety Valve. Excessive discharge from the drain line or operation of the small auxiliary relief valve opposite the drain can mean a malfunction within the system. Switch off the energy source and call a plumber or service person.

INSTALLATION REQUIREMENTS

In addition to these instructions, PTR Valves must be installed in accordance with AS/NZS3500 National Plumbing and Drainage Code. All local government requirements must be met and the PTR must be installed in line with the water heater manufacturer's instructions. Valve rated to 10Kw.

The PTR valve to be fitted must comply with the water heater manufacturer's rating label. The kw rating of the valve should be greater than the kw rating of the water heater. All this information is found on the rating plate of the valve, and on the rating label on the side of the heater.

*Australian Valve Group (AVG) Pressure & Temperature Relief valves should be installed by a licensed plumber in accordance with AS/NZS3500.

* If the valve probe is damaged in any way do not install the valve. Return it to your valve supplier and obtain a replacement. Clean out any foreign matter from the threaded inlet water connection to the water heater.

*Flush the plumbing lines before connection. Deposits left in the line can lodge under the valve seat causing the valve to leak.

*Apply thread seal tape to the thread. Be sure not to use excessive amounts of thread seal that could hang over the thread, break off and lodge under the valve seat, causing it to leak.

*Screw the valve into the PTR socket.

*Do not use a wrench on the valve body. Use the spanner flats provided.

*No valve, taps, or other isolating valves are to be fitted between the PTR and the water heater.

*Install a drain line of the same nominal pipe size as the valve, in accordance with AS/NZS3500.4. The drain line must have a continuous fall.

*Test the manual relief by lifting the lever. Water should flow out of the relief valve. It is recommended that the manual relief be operated every 6 months, so as to flush out any deposits that may accumulate under the seal.

*CAUTION: "Danger of scalding" This valve relieves hot water.

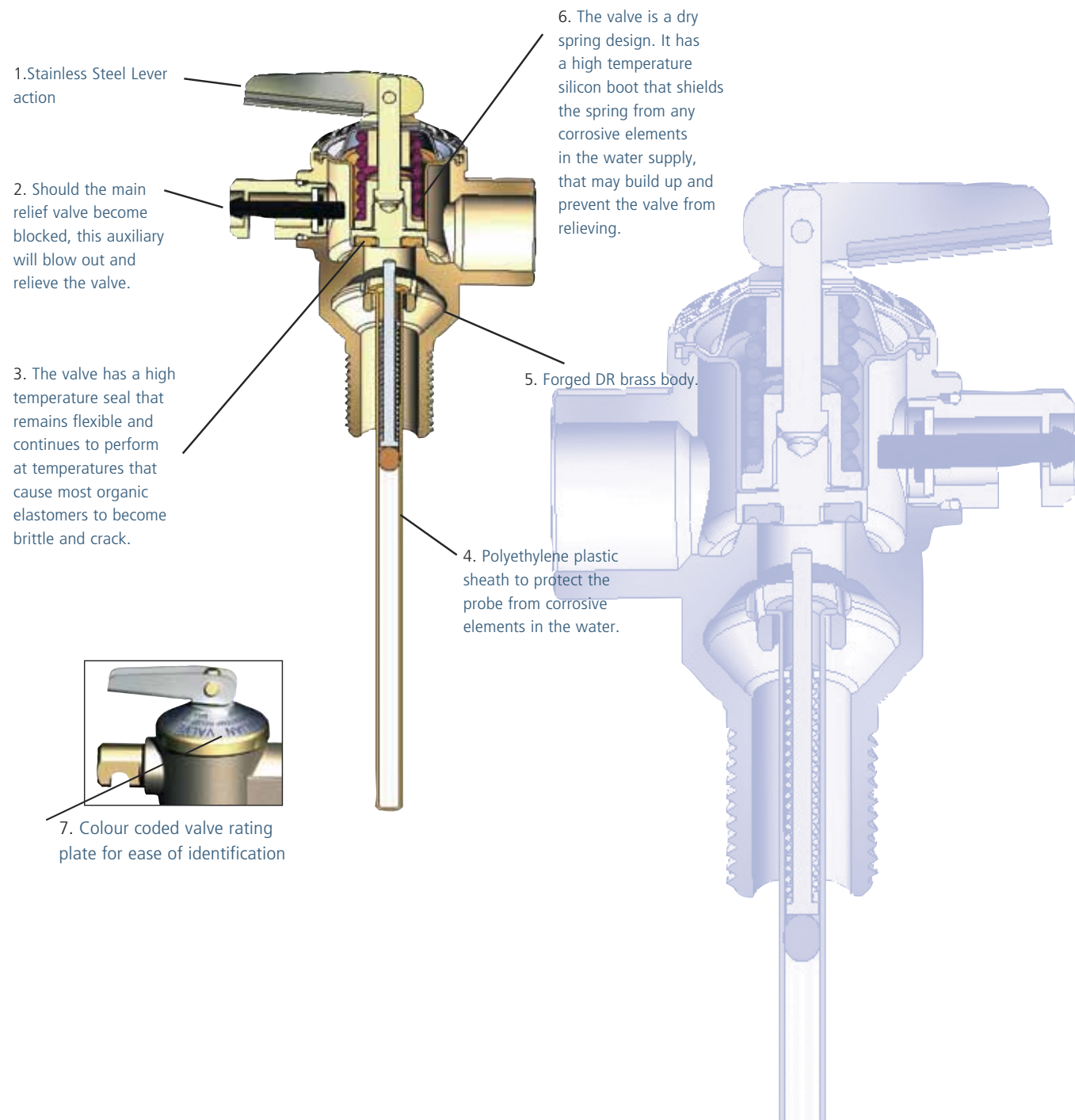

Each valve is individually tested and calibrated to ensure that it meets the correct pressure specifications. Designed and manufactured to meet Australian Standard AS1357.1, under licence No. 2639 and meets AS4020, Drinkable Water Standard. Manufactured under Quality Assurance ISO 9001 and ISO 9002 (UK) Suitable for either horizontal or vertical installations. The valve is designed to automatically reset after each action.

Pressure & Temperature Relief Valve



AVG

Australian Valve Group

Australian Valve Group (Head Office)
 Unit 2, 9-11 Noble St, Kewdale, Perth, Western Australia 6105
 Fax: +61 8 9353 2689 Tel: 1800 AVG AUS (284 287)

AVG
 Australian Valve Group

FOR MORE INFORMATION VISIT OUR WEBSITE AT WWW.AVG.NET.AU

Pressure and Temperature Relief Valve

PTR

PTR-HTT

PTR VALVE FUNCTION

The Pressure and Temperature Relief valve (PTR) is designed to relieve the increase in pressure caused by water expansion during the normal heating cycle. The valve will then relieve the increase in pressure by releasing drips of hot water to the drain line. Should the electrical temperature cut-out device cease to operate correctly, the water will overheat. The temperature probe will then open the PTR valve and discharge hot water to the drain line. It is recommended that an ECV be fitted to the cold water supply line. This will relieve cold water, not hot water, during the heating cycle, saving energy and increasing the life of the PTR. Some local governments make it mandatory to install an ECV in the cold water line. PTR and ECV valves are safety valves and should be replaced every 4 years.

INLET PRESSURE CONTROL

High pressure may cause excessive discharge and possible premature failure of the operating relief valve (see table). The maximum water pressure usually occurs during the night, at the time of lowest water usage. In any mains pressure water heater installation if the water pressure exceeds 80% of the nominal set pressure of the operating relief valve, a Pressure Limiting Valve must be fitted to the cold inlet. If a cold water expansion control valve is fitted it will have a lower set pressure than the PTR valve and therefore will be the main operating relief valve.

SET PRESSURES FOR WATER HEATER VALVES

PTR Valve Setting kpa	Without Expansion Control Valve		With Expansion Control Valve		
	PLV required if mains pressure exceeds:	Pressure Limiting Valve setting kpa	Expansion Control Valve setting kpa	PLV required if mains pressure exceeds:	Pressure Limiting Valve setting kpa
700	680	500	700	550	350
850	680	500	700	550	350
1000	800	600	850	680	500
1400	1120	600	1200	960	600

PTR SPECIFICATIONS

Model	DN SIZE	COLOUR CODE	PRESSURE RATING	INLET	OUTLET	EXPANSION RATING
PTR15/1400	15	RED	1400 kpa	1/2" male	1/2" female	10 KW
PTR15/1000	15	GREEN	1000 kpa	1/2" male	1/2" female	10 KW
PTR15/850	15	BLUE	850 kpa	1/2" male	1/2" female	10 KW
PTR15/700	15	BLACK	700 kpa	1/2" male	1/2" female	10 KW
PTR20/1000	20	BLACK	1000 kpa	3/4" male	3/4" female	46 KW
PTR20/850	20	BLUE	850 kpa	3/4" male	3/4" female	46 KW
PTR20/700	20	BLACK	700 kpa	3/4" male	3/4" female	46 KW

COLOUR RATING PLATE	ECV VALVES	PTR VALVES
Black	ECV 15/600	PTR 15/700
Black	ECV 20/600	PTR 20/700
Blue	ECV 15/700	PTR 15/850
Blue	ECV 20/700	PTR 20/850
Green	ECV 15/850	PTR 15/1000
Green		PTR 15/1000
Green	ECV 20/850	PTR 20/1000
Red	ECV 15/1200	PTR 15/1400
Red		PTR 15/1400
Red	ECV 15/1200	PTR 15/1400-HTT
Red	ECV 20/1200	
Orange	ECV 15/1400	

Rating plate colours

The valve rating plates are colour coded to make selecting the correct valve easy. Simply match the PTR valve to an ECV with a rating plate of the same colour.



Insulation available according to AS3500.

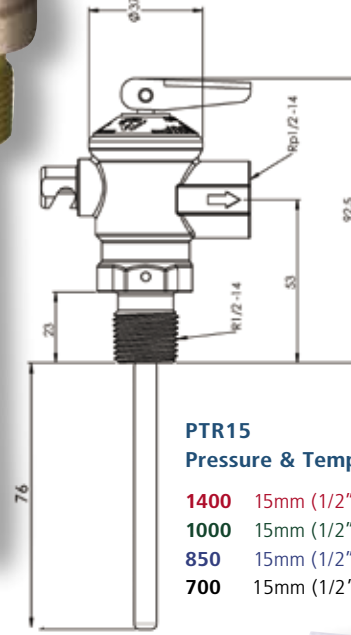
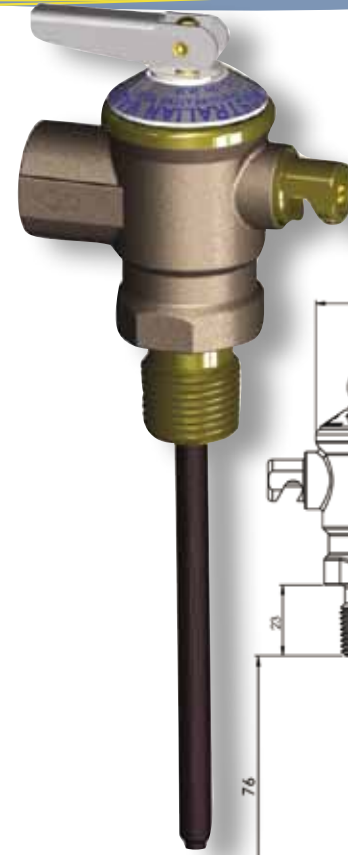

PTR15
Pressure & Temperature Relief Valves

- 1400 15mm (1/2") BSP
- 1000 15mm (1/2") BSP
- 850 15mm (1/2") BSP
- 700 15mm (1/2") BSP

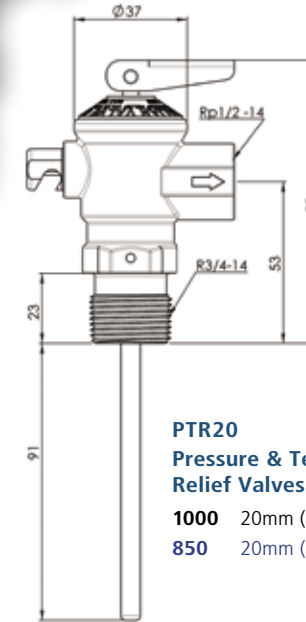
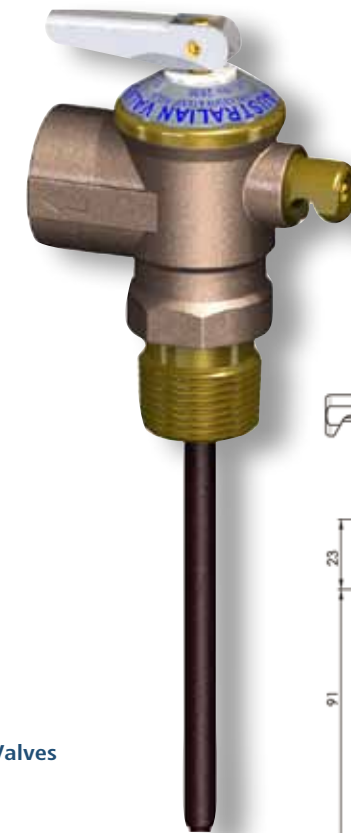

PTR20
Pressure & Temperature Relief Valves

- 1000 20mm (3/4") BSP
- 850 20mm (3/4") BSP

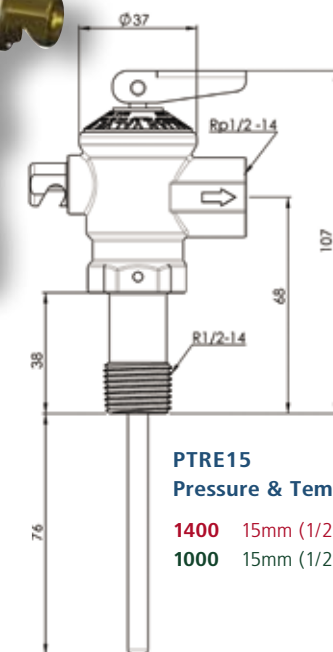
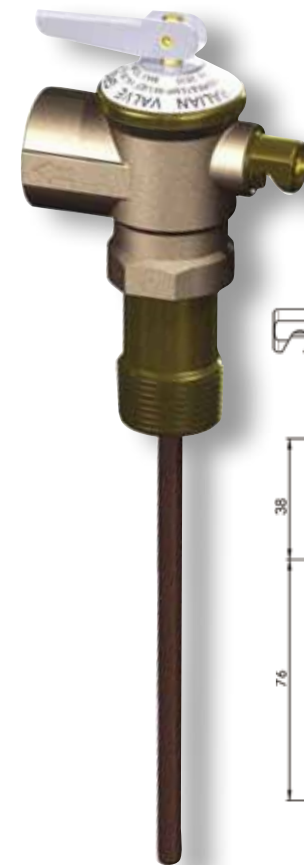

PTRE15
Pressure & Temperature Relief Valves

- 1400 15mm (1/2") BSP – 25mm Extended Body
- 1000 15mm (1/2") BSP – 25mm Extended Body



PTR 15-20/850HL
Pressure & Temperature Relief Valve complete with 360° swivel hot water outlet

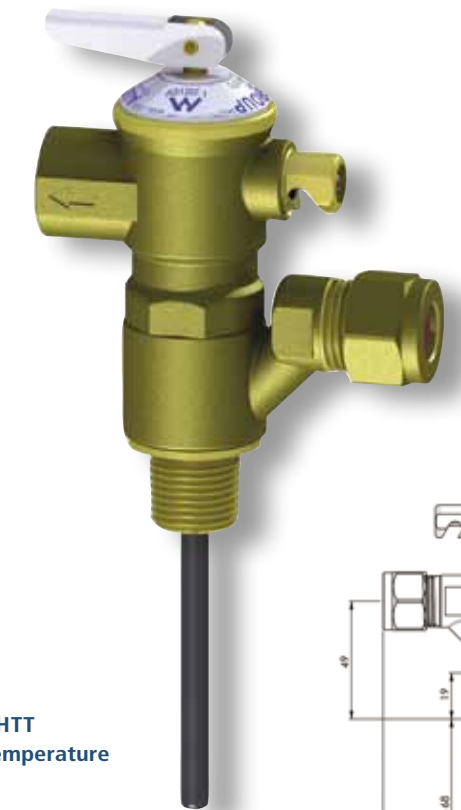
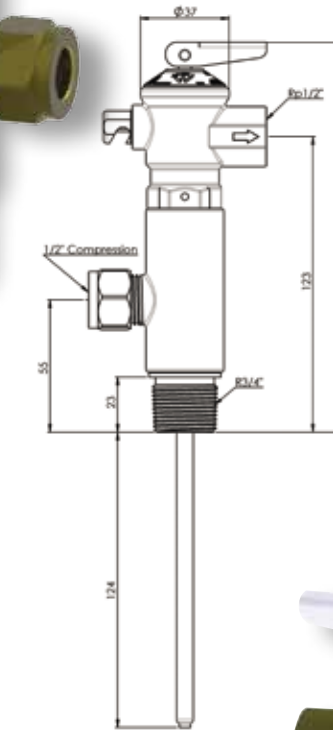

PTR 15/1400HTT
Pressure & Temperature Relief Valve

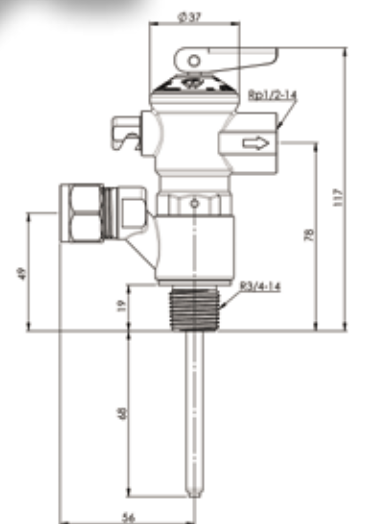

Insulation available according to AS3500.



Features

- 360° Swivel Hot Water Outlet
- Forged DR Brass Body
- Individually tested & calibrated
- Insulation & cables included

WARRANTY
This valve is factory set and cannot be serviced or repaired in the field. The Australian Valve Group (AVG) will not honour any warranty claim where these instructions have not been followed, or where the valve has been tampered with or subjected to obvious abuse.

DISCLAIMER
Every care has been taken in the preparation of these instructions, which have been issued as a guide only. Compliance with the requirements of Local Authorities is required at all times. These requirements may change from time to time. Always be aware of the local requirements. Subject to any statutory obligations and manufacturers warranties no liability can be accepted for any losses, consequential or otherwise which may arise or be said to have arisen from relying upon the contents of this installation instruction. As to the fitness of any particular product for any particular purpose, use or application, The Australian Valve Group Pty Ltd reserves the right to modify designs and specifications and to withdraw and introduce products at any time without notice.